

# REPLACEMENT RINGS

REVISIONS			
REV	DESCRIPTION	DATE	APPROVED

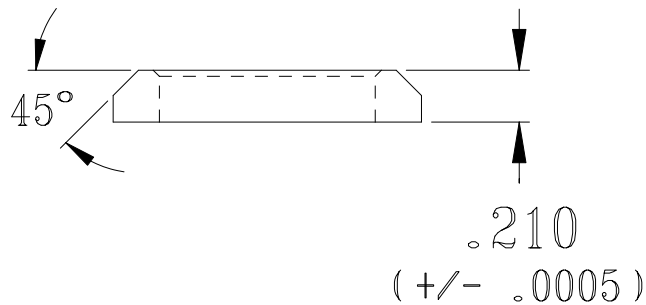
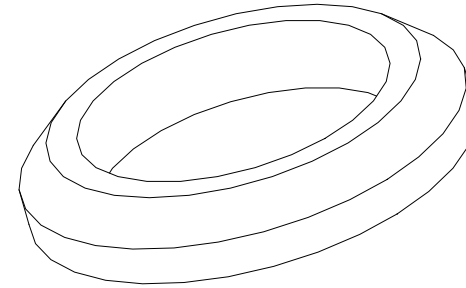
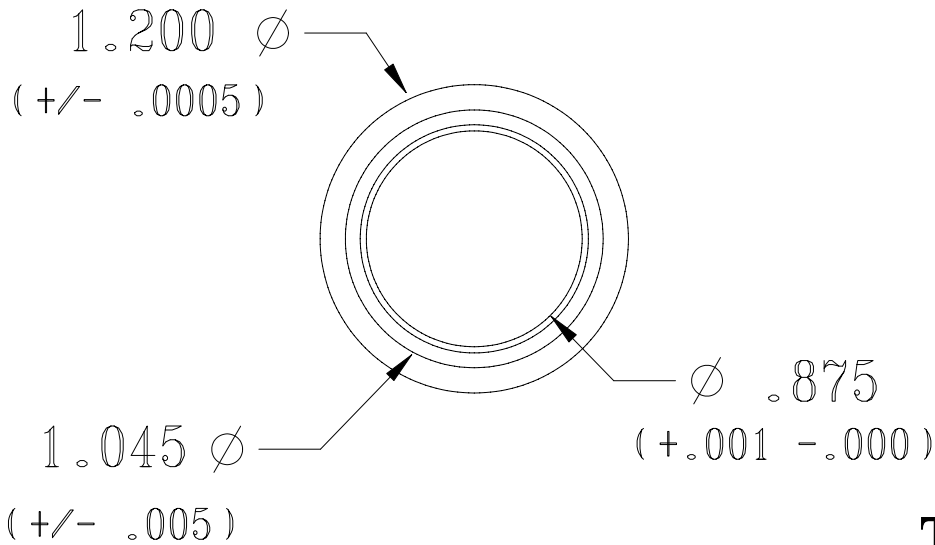

45° x .025 CHAMFER ON  
BOTH SIDES OF THE I.D.

The Airo Tool Replacement Ring is used with the 3 piece Blow Pin Assembly. This assembly replaces the one piece pull up cutter. The illustration shows a 1.200 diameter. This is for an example the o.d.'s come in many sizes to fit your needs.

DRAWN BY	<i>DAN</i>	SIZE	A4	MATERIAL	D2	DWG NO.	C875210-1200A	REV	
DATE	09/02/08	SCALE	1:1	H.T.	59/60	SALESMAN:	<i>DAN</i>		